

Pneumatic Rotary Actuators

SPECIFICATIONS



(AP SERIES)



(APM SERIES)



• Pressure range:

2 bar (29 psig) to 8 bar (116 psig) double acting
3 bar (44 psig) to 8 bar (116 psig) spring return
max. working pressure 10 bar (145 psig).

• Supply:

filtered dry or lubricated air.
For non corrosive gas water or light hydraulic oil
please check with Sirca's technical department.

• Temperature range:

STD -20°C (-4°F) a + 80°C (175°F)
on request +20°C (+68°F) a +150°C (302°F)
on request - 50°C (-58°F) a +100°C (212°F).

• Rotation:

counterclockwise when Port'A is pressurized;
clockwise when PORT 'B' is pressurized
and for spring return actuators (see principle of operation).

• Stroke:

90° with standard adjustment $\pm 3^\circ$ (AP Series)
or bi-directional travel adjustment $\pm 5^\circ$ (APM Series).

• Lubrication:

all moving parts are factory lubricated for
cycle life of the actuator.

• Construction:

in accordance to "Equipment or Protective system
intended for use in potentially explosive atmosphere
directive 94/9/CE".

Suitable for indoor and outdoor installation.

• Connections:

bottom drilling to match valve is in accordance
with ISO 5211/DIN 3337 Interface for solenoid valve,
shaft top end and top drilling to assemble accessories
are in accordance with VDI / VDE 3845, NAMUR.

• Inspection:

each unit is hydraulically tested and certified
and guaranteed for a minimum of 500.000 moves.

MATERIALS

• Actuator body:

extruded aluminium alloy.

• End cap:

pressure die casting aluminium alloy

• Pinion:

E.N.P. Carbon steel or 303 S.S.

• Piston:

pressure die casting aluminium alloy

• Guide:

Acetal resin

• "O" rings:

Buna-n (NBR), FKM or Silicone

• Springs:

Epoxy coated spring steel

• Screws and nuts:

Stainless Steel

Foreword

Thanks to its achieved experience in the field of the automation, since last 1979 SIRCA INTERNATIONAL has been producing and selling its rotary pneumatic actuators series AP.

The actuators are of rack and pinion type, and a kinetic energy turns a linear moving into a rotary one. The opposed movement of the pistons is protected, as performed in a cylinder, on which extremities two end-cups are inserted.

They can be easily mounted on each type of equipment, and have light weight.

You can easily mount any fitting on them (limit switches, solenoid valves, positioners, disengageable gear boxes, levers, and so on).

They find their best appliance on the actioning of ball, butterfly and plug valves, which have a rotation angle of 90°; they can also be used on other equipment, having rotation angle of 120°-180°.

The torque they generate is proportional to the air supply pressure; therefore, a higher supply pressure corresponds to a higher torque.

Both double acting and spring return actuators have twin cylinders horizontally opposed and incorporate piston guides to ensure correct contact between the rack and pinion, at any pressure.

Double acting and spring return models are of similar overall size.

Sirca Actuators offer an excellent cost-performance ratio

SIRCA
INTERNATIONAL S.P.A. (ITALY)



SALES AND ACCOUNTING DEPARTMENT WAREHOUSE
20060 TREZZANO ROSA (MI - ITALY) - Via Trieste n° 8
Phone ++39 02 92010204 (six lines)
Fax ++39 02 92011954 Sales and Accounting Dept.
Fax ++39 02 92010216 Purchase and Technical Dept.
E-mail: sirca@tin.it - web site: www.sircainternational.com

PNEUMATIC ROTARY ACTUATORS

AIR CONSUMPTION FOR STROKE AIR (FREE AIR) in liters

Model	AP1 DA/SR	AP2 DA/SR	AP3 DA/SR	AP3.5 DA/SR	AP4 DA/SR	AP4.5 DA/SR	AP5 DA/SR	AP5.5 DA/SR	AP6 DA/SR	AP8 DA/SR	AP10 DA/SR
Counter clockwise	0.08	0.12	0.24	0.48	0.68	1	1.4	1.6	3.2	5.3	14.2
Clockwise (DA only)	0.10	0.16	0.44	0.56	0.96	1.6	2.16	2.56	4	8.6	16.5

OPENING / CLOSING TIME (sec) at 5.6 bar/80 p.s.i.

Model	AP1	AP2	AP3	AP3.5	AP4	AP4.5	AP5	AP5.5	AP6	AP8	AP10
Double Acting	Less than 1 Sec	Less than 1 Sec	Less than 1 Sec	Less than 1 Sec	Less than 1 Sec	Less than 1 Sec	Less than 1.25 Secs	Less than 1.5 Secs	1.5÷2 Secs	3÷4 Secs	5÷6 Secs
Spring Return	Less than 1 Sec	Less than 1 Sec	Less than 1 Sec	Less than 1.5 Sec	Less than 1.5 Secs	Less than 1 Sec	1.5÷2 Secs	2 Secs	2÷3 Secs	4÷6 Secs	7÷8 Secs

*WEIGHTS in Kgs

Model	AP1	AP2	AP3	AP3.5	AP4	AP4.5	AP5	AP5.5	AP6	AP8	AP10
Double Acting	1.15	1.60	2.80	4.28	5.80	8.26	11.63	14.15	21.70	40.10	110
Spring Return*	1.27	1.85	3.36	4.91	6.92	9.72	14.15	17.35	25.90	48.62	128

* Weights considering 6 (six) springs on each side of the caps

DOUBLE ACTING ACTUATOR (DA) ISO 5211

PRINCIPLE OF OPERATION

Counter clockwise output operation is achieved by inserting pressure into **Port "A"**, to force the pistons apart thus rotating the actuator pinion counter clockwise. During the operation, air from the outer chambers is exhausted through **Port "B"**. Clockwise output operation is achieved by reverse of the above and inserting pressure into **Port "B"**.

COUNTER CLOCKWISE OUTPUT ROTATION

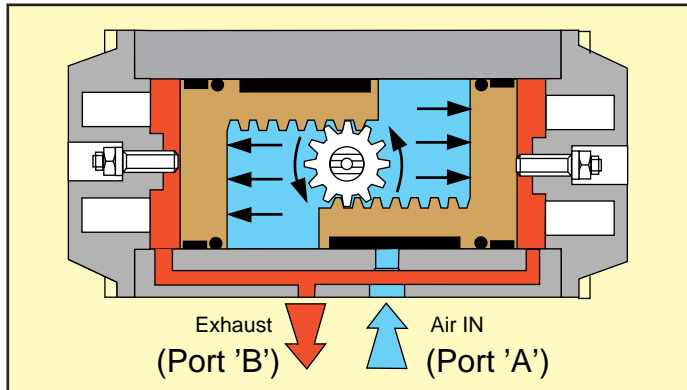

CLOCKWISE OUTPUT ROTATION

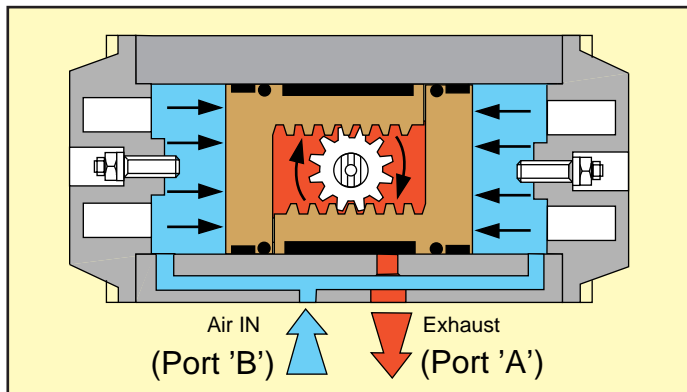

SPRING RETURN ACTUATOR (SR) ISO 5211

PRINCIPLE OF OPERATION

Pressure applied to **Port "A"** will cause the inner chambers to be pressurised, forcing the pistons outward to compress the springs. The pinion is rotated counter clockwise. Upon release of pressure through **Port "A"** the springs will exert pressure to close the pistons and rotate the pinion clockwise rapidly. This action will often be used to close a 90° turn valve in shutdown mode.

COUNTER CLOCKWISE OUTPUT ROTATION

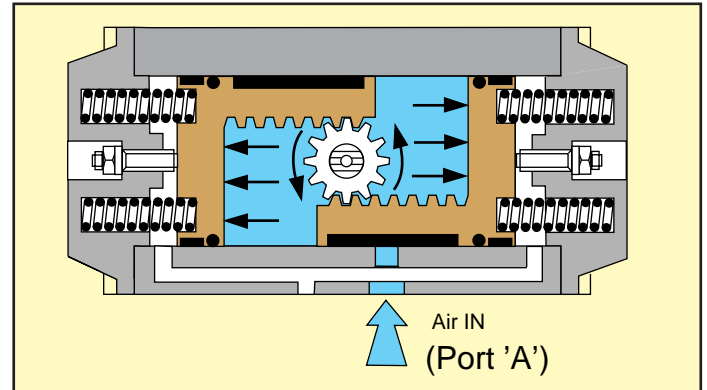

CLOCKWISE OUTPUT ROTATION

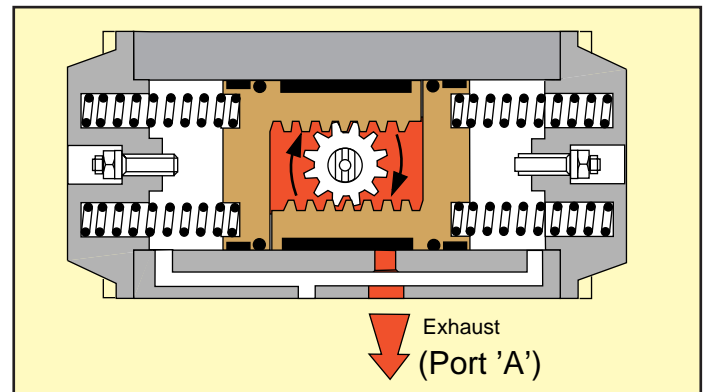

TORQUE OUTPUT DOUBLE ACTING ACTUATORS (DA) in Nm

Model	OPERATING PRESSURE - bar / p.s.i.						
	2	3	4	5	6	7	8
	30	44	58	73	87	102	116
AP1 DA	5.9	8.9	11.8	14.8	17.7	21.7	24.8
AP2 DA	9.4	14.1	18.8	23.5	28.2	32.9	37.6
AP3 DA	20	30	40	50	60	70	80
AP3.5 DA	34	51	68	85	102	119	136
AP4 DA	48	71	95	119	142	168	192
AP4.5 DA	87.2	130.8	174.4	218	261.6	305.2	348.8
AP5 DA	111	167	222	278	333	388.5	444
AP5.5 DA	157.6	236.4	315.3	394.1	473	551.8	630.6
AP6 DA	227	340	454	567	680	794.5	908
AP8 DA	426	638	851	1064	1276	1491	1704
AP10 DA	1078	1617	2156	2695	3234	3773	4312

NOTE: The output torque of selected actuator should never be less the required valve torque

PNEUMATIC ROTARY ACTUATORS

TORQUE OUTPUT SPRING RETURN ACTUATORS (SR) in Nm

Model	N° of Springs for each side of cap	OPERATING PRESSURE - bar / p.s.i.													
		3 44		4 58		5 73		6 87		7 102		8 116		SPRING STROKE	
		0°	90°	0°	90°	0°	90°	0°	90°	0°	90°	0°	90°	90°	0°
AP1SR	2	6.5	5.4	9.4	8.3	12.4	11.3	15.3	14.2	19.3	18.2	22.4	21.3	3.5	2.4
	3	5.3	3.7	8.2	6.6	11.2	9.6	14.1	12.5	18.1	16.5	21.2	19.6	5.2	3.6
	4	4.1	1.9	7.0	4.8	10.0	7.8	12.9	10.7	16.9	14.7	20.0	17.8	7.0	4.8
	5	=	=	3.1	2.7	8.8	6.1	11.7	9.0	15.7	13.0	18.8	16.1	8.7	6.0
	6	=	=	=	=	7.6	4.3	10.5	7.2	14.5	11.2	17.6	14.3	10.5	7.2
AP2SR	2	10.3	8.5	15.0	13.2	19.7	17.9	24.4	22.6	29.1	27.3	33.8	32.0	5.6	3.8
	3	8.4	5.7	13.1	10.4	17.8	15.1	22.5	19.8	27.2	24.5	31.9	29.2	8.4	5.7
	4	=	=	11.2	7.6	15.9	12.3	20.6	17.0	25.3	21.7	30.0	26.4	11.2	7.6
	5	=	=	=	=	14.0	9.5	18.7	14.2	23.4	18.9	28.1	23.6	14.0	9.5
	6	=	=	=	=	12.1	6.7	16.8	11.4	21.5	16.1	26.2	20.8	16.8	11.4
AP3SR	2	22.0	18.0	32.0	28.0	42.0	38.0	52.0	48.0	62.0	58.0	72.0	68.0	12.0	8.0
	3	18.0	12.0	28.0	22.0	38.0	32.0	48.0	42.0	58.0	52.0	68.0	62.0	18.0	12.0
	4	=	=	24.0	16.0	34.0	26.0	44.0	36.0	54.0	46.0	64.0	56.0	24.0	16.0
	5	=	=	=	=	30.0	20.0	40.0	30.0	50.0	40.0	60.0	50.0	30.0	20.0
	6	=	=	=	=	26.0	14.0	36.0	24.0	46.0	34.0	56.0	44.0	36.0	24.0
AP3.5SR	2	41.5	30.0	58.5	47.0	75.5	64.0	92.5	81.0	109.5	98.0	126.5	115.0	21.0	9.5
	3	32.0	20.0	49.0	37.0	66.0	54.0	83.0	71.0	100.0	88.0	117.0	105.0	31.0	19.0
	4	=	=	43.0	20.0	60.0	37.0	77.0	54.0	94.0	71.0	111.0	88.0	48.0	25.0
	5	=	=	=	=	53.0	33.0	70.0	50.0	87.0	67.0	104.0	84.0	52.0	32.0
	6	=	=	=	=	47.0	22.0	64.0	39.0	81.0	56.0	106.4	73.0	63.0	38.0
AP4SR	2	52.7	42.4	76.7	66.4	100.7	90.4	123.7	113.4	149.7	139.4	173.7	175.2	28.6	18.3
	3	43.0	28.0	67.0	52.0	91.0	76.0	114.0	99.0	140.0	125.0	164.0	153.6	43.0	28.0
	4	=	=	58.0	38.0	82.0	62.0	105.0	85.0	131.0	111.0	155.0	132.0	57.0	37.0
	5	=	=	=	=	73.0	47.0	96.0	70.0	122.0	96.0	146.0	110.4	72.0	46.0
	6	=	=	=	=	64.0	33.0	87.0	56.0	113.0	82.0	137.0	88.8	86.0	55.0
AP4.5SR	2	96.8	77.5	140.4	121.1	184.0	164.7	227.6	208.3	271.2	251.9	314.8	295.5	53.3	34.0
	3	79.8	50.9	123.4	94.5	167.0	138.1	210.6	181.7	254.2	225.3	297.8	268.9	79.9	51.0
	4	62.8	24.2	106.4	67.8	150.0	111.4	193.6	155.0	237.2	198.6	280.8	242.2	106.6	68.0
	5	=	=	89.4	41.1	133.0	84.7	176.6	128.3	220.2	171.9	263.8	215.5	133.3	85.0
	6	=	=	72.4	14.4	116.0	58.0	159.6	101.6	203.2	145.2	246.8	188.8	160.0	102.0
AP5SR	2	123.7	99.4	178.7	154.4	234.7	210.4	289.7	265.4	345.2	320.9	400.7	376.4	67.6	43.3
	3	103.0	66.0	158.0	121.0	214.0	177.0	269.0	232.0	324.5	287.5	380.0	343.0	101.0	64.0
	4	=	=	136.0	87.0	192.0	143.0	247.0	198.0	302.5	253.5	358.0	309.0	135.0	86.0
	5	=	=	=	=	170.0	109.0	225.0	164.0	280.5	219.5	336.0	275.0	169.0	108.0
	6	=	=	=	=	148.0	75.0	203.0	130.0	258.5	185.5	314.0	241.0	203.0	130.0
AP5.5SR	2	176.2	132.8	258.7	215.3	337.5	294.1	416.4	373.0	495.2	451.8	574.0	530.6	100.0	56.6
	3	147.9	82.8	230.4	165.3	309.2	244.1	388.1	323.0	466.9	401.8	545.7	480.6	150.0	84.9
	4	119.5	32.8	202.0	115.3	280.8	194.1	359.7	273.0	438.5	351.8	517.3	430.6	200.0	113.3
	5	=	=	173.7	65.3	252.5	144.1	331.4	223.0	410.2	301.8	489.0	380.6	250.0	141.6
	6	=	=	145.3	15.3	224.1	94.1	303.0	173.0	381.8	251.8	460.6	330.6	300.0	170.0
AP6SR	2	257.0	200.0	371.0	314.0	484.0	427.0	597.0	540.0	711.5	645.5	825.0	768.0	140.0	83.0
	3	215.0	130.0	329.0	244.0	442.0	357.0	555.0	470.0	669.5	584.5	783.0	698.0	210.0	125.0
	4	=	=	287.0	174.0	400.0	287.0	513.0	400.0	627.5	514.5	741.0	628.0	280.0	167.0
	5	=	=	=	=	358.0	217.0	471.0	330.0	585.5	444.5	699.0	558.0	350.0	209.0
	6	=	=	=	=	316.0	147.0	429.0	260.0	543.5	374.5	657.0	488.0	420.0	251.0
AP8SR	2	478.0	386.0	691.0	599.0	904.0	812.0	1116.0	1024.0	1331.0	1239.0	1704.0	1452.0	252.0	160.0
	3	398.0	260.0	611.0	473.0	824.0	686.0	1036.0	898.0	1251.0	1113.0	1464.0	1326.0	378.0	240.0
	4	=	=	531.0	347.0	744.0	560.0	956.0	772.0	1171.0	987.0	1384.0	1200.0	504.0	320.0
	5	=	=	=	=	664.0	434.0	876.0	646.0	1091.0	861.0	1304.0	1074.0	630.0	400.0
	6	=	=	=	=	584.0	308.0	796.0	520.0	1011.0	735.0	1224.0	948.0	756.0	480.0
AP10SR	2	1181.0	957.0	1720.0	1496.0	2259.0	2035.0	2798.0	2574.0	3337.0	3113.0	3876.0	3652.0	660.0	436.0
	3	963.0	628.0	1502.0	1167.0	2041.0	1706.0	2580.0	2245.0	3119.0	2784.0	3658.0	3323.0	989.0	654.0
	4	=	=	1284.0	837.0	1823.0	1376.0	2362.0	1915.0	2901.0	2454.0	3440.0	2993.0	1319.0	872.0
	5	=	=	=	=	1605.0	1046.0	2144.0	1585.0	2683.0	2124.0	3222.0	2663.0	1649.0	1090.0
	6	=	=	=	=	=	=	1909.0	1254.0	2448.0	1793.0	2987.0	2332.0	1980.0	1325.0

NOTE: The output torque of selected actuator should never be less the required valve torque

MOUNTING VARIATIONS

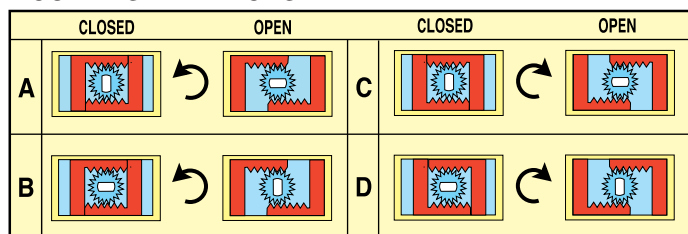

RIGHT ARRANGEMENT OF SPRINGS

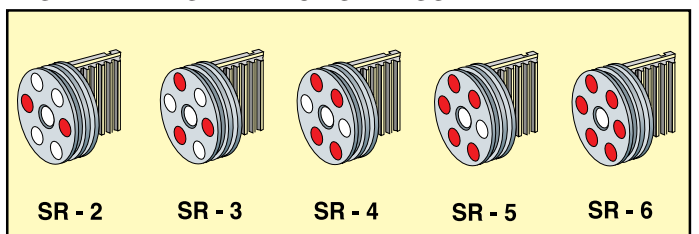

PNEUMATIC ROTARY ACTUATORS

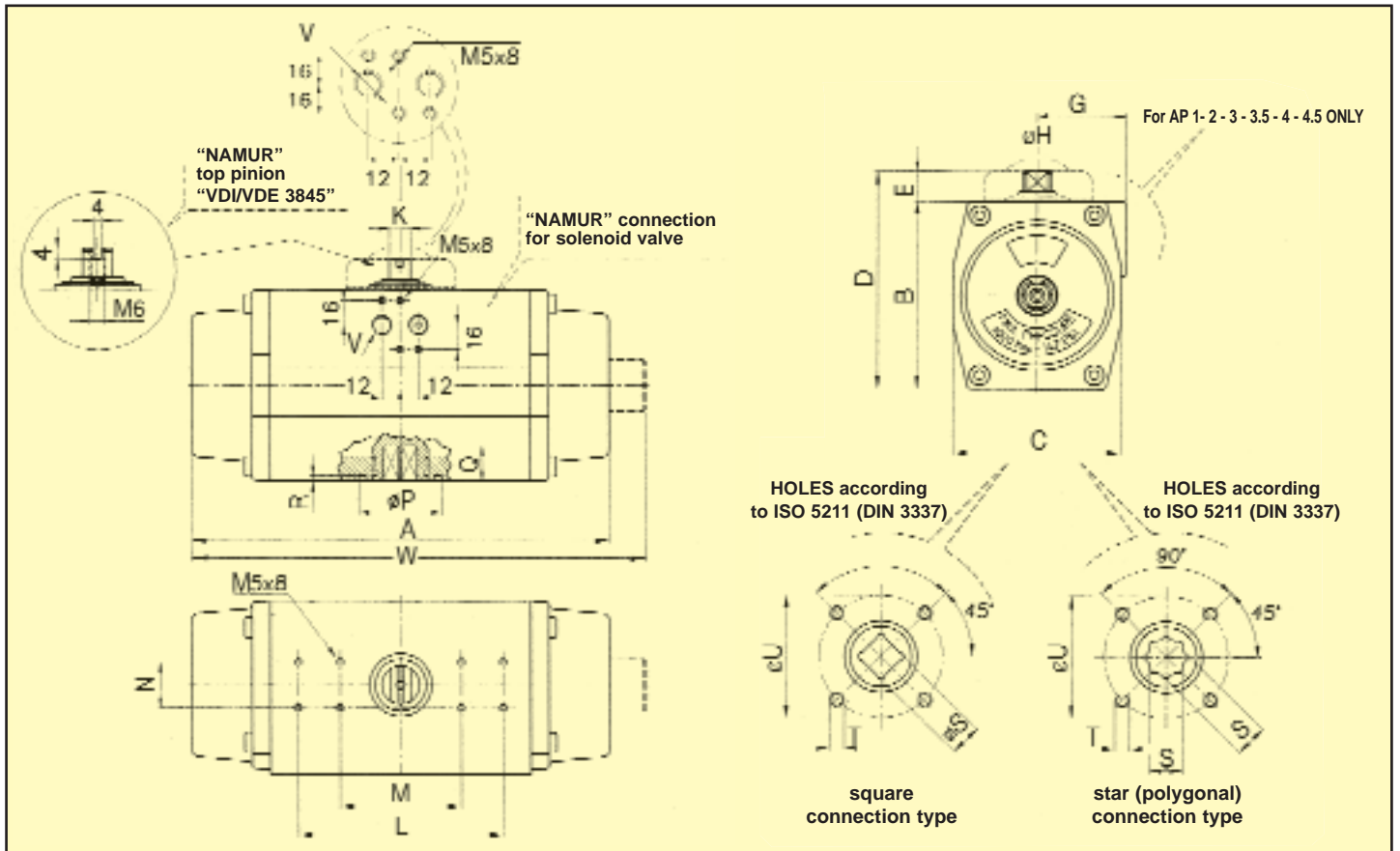

DIMENSIONS in mm

Model	A	W*	B	C	D	E	F	G	H	K	L	M	N	P	Q	R	∠S-S	T	U	V	ISO 5211 STD.	ISO 5211 SPECIAL
AP1	142	162	67	60	87	20	42	41	12	8	-	80	30	25	10	2	9/11**	M5/M6	36/50	1/8"	F03/F05	F04
AP2	155	171	83	73	103	20	42	44.5	12	8	-	80	30	30/35	12	2	11/14**	M5/M6	42/50	1/4"	F04/F05***	-
AP3	213	240	100	85	120	20	50	49.5	14	10	-	80	30	35	16	3	14/17**	M6/M8	50/70	1/4"	F05/F07	-
AP3.5	236	268	110	98	130	20	50	53	19	14	-	80	30	55	20	3.5	17/22**	M8	70	1/4"	F07	F05
AP4	276	304	125	110	145	20	50	58	19	14	-	80	30	55	20	3.5	17/22	M8/M10	70/102	1/4"	F07/F10	-
AP4.5	310	350	142	128	172	30	58	69	28	20	130	80	30	70	24	3.5	17**/22	M10	102	1/4"	F10	F07
AP5	366	405	155	140	185	30	-	-	28	20	130	80	30	70	24	3.5	17**/22	M10	102	1/4"	F10	F07/F12
AP5.5	388	442	176	160	206	30	-	-	36	28	130	80	30	85	29	3.5	22**/27	M12	125	1/4"	F12	F10
AP6	468	500	200	175	230	30	-	-	36	28	130	80	30	85	29	3.5	22**/27	M12	125	1/4"	F12	F10
AP8	563	612	250	215	300	50	-	-	48	32	130	-	30	100	38	5	27**/36	M16	140	1/4"	F14	F12
AP10	750	838	335	290	385	50	-	-	48	32	130	-	30	130	50	5	36**/46	M20	165	1/4"	F16	F14

*Dimension W only for APM series

**Dimension on request

***To be chosen when ordering

PNEUMATIC ACTUATOR AP0DA MODEL

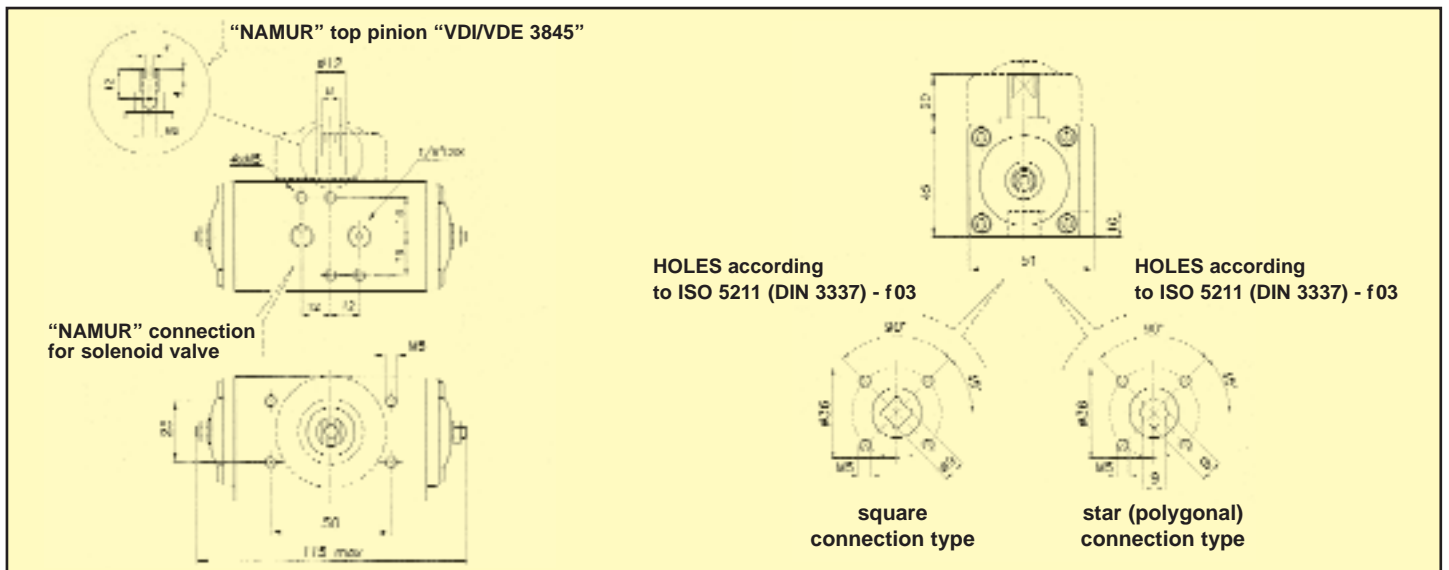

TORQUE OUTPUT DOUBLE ACTING (DA) in Nm

OPERATING PRESSURE							
bar	2	3	4	5	6	7	8
p.s.i.	29	44	58	73	87	102	116
Nm	2.4	3.6	4.8	6	7.3	8.5	9.7

AIR CONSUMPTION FOR STROKE (FREE AIR) in Liters

Counter Clockwise	0.04
Clockwise (DA only)	0.05

OPENING/CLOSING TIME (sec.) at 5.6 bar/80 p.s.i.

Double Acting	Less Than 0.5 sec
---------------	-------------------

WEIGHT: Kg 0.58